

AVIATOR

USER MANUAL



Contents

Product Profile

Linking the Remote Controller	4
Remote Controller Overview	7
Profile	9
Preparing the Remote Controller	10
Remote Controller Operations	
Motor starting and stopping	13
Flight mode	14
RTL mode (1)	15
RTL mode (2)	16
RTK Functions	
Video Transmission Descriptions	19

Fly Dynamics App

Pre-flight verification procedures	21
Manual Flight	22
Mission Flight	26
Aircraft Settings	37
Sensors Calibration	38
Radio Calibration	40
Application Settings	41

Flight

Remote controller precautions	45
Remote controller external inspection	

Appendix

Specifications	47
App updates	48
Customer Support Center	49

Product Profile

This Section describes the features of the product, guide the preparation of the aircraft before flight, and lists the components of the aircraft and remote controller.

Linking The Remote Controller

The aircraft and remote controller must be linked before use. Follow these steps to link a new remote controller.

1. Turn on the remote control and enter the main interface, as shown in the figure below, slide down the screen to start setting the binding, click to enter the App Settings option, and select the DLink option.

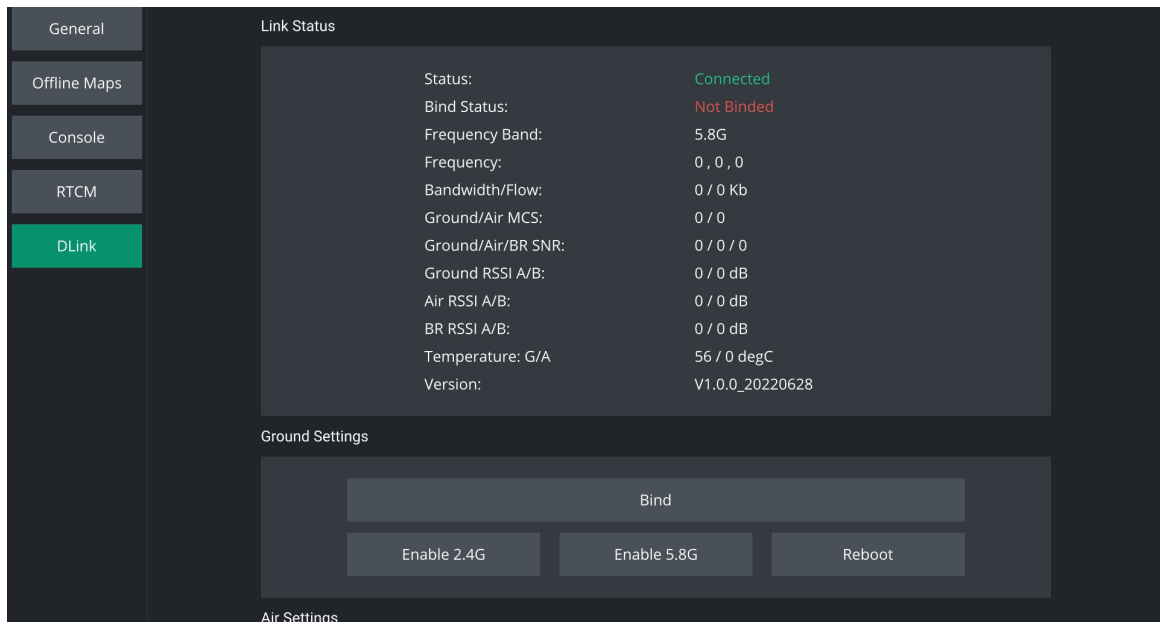

2. Align the tail of the aircraft to open a hole with slender hard objects like a screwdriver, reach forward to press connect button of the Transmission Module for 2 seconds until the indicator flashes quickly. The aircraft is ready to be connected.

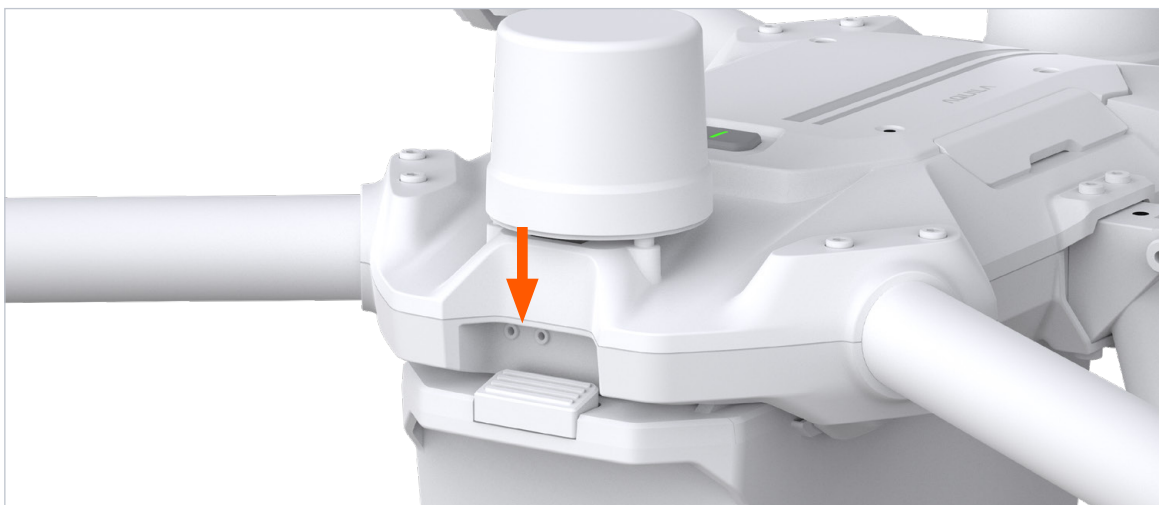

3. Click "Bind" to bind.



4. When connection is completed, the Transmission Module indicator will be solid and then be off. The controller will receive data from Aircraft. Bind Status will show as "Binded" in green.

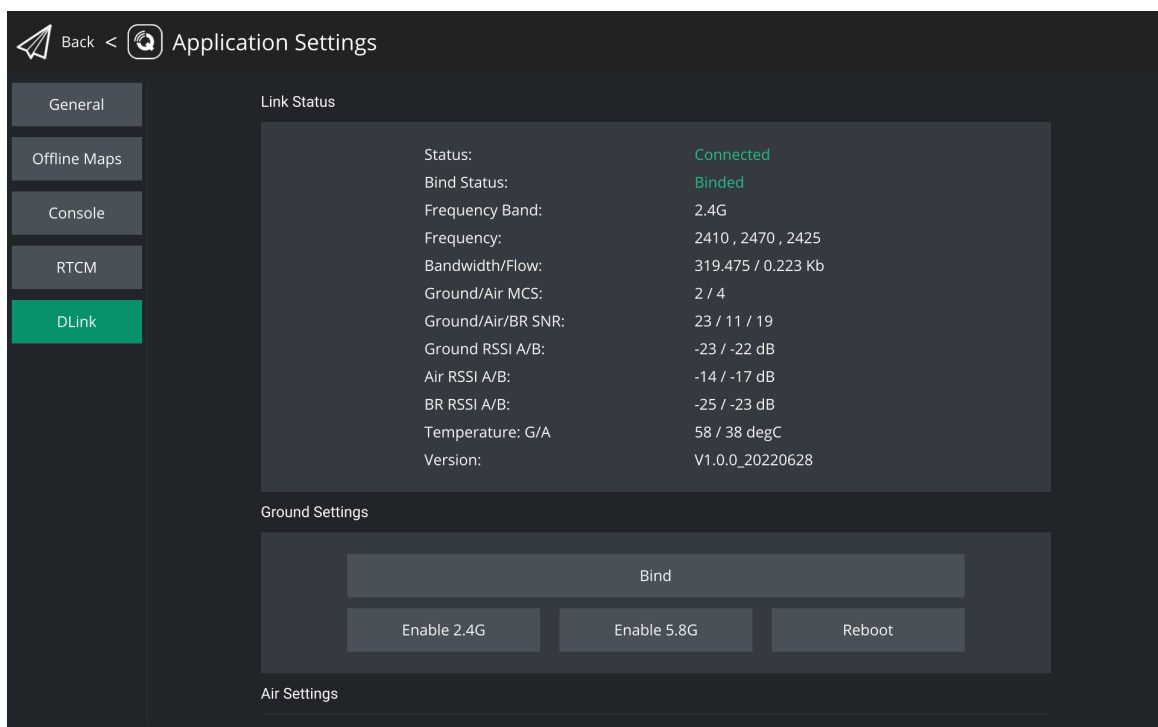

Note:

The factory default is 5.8Ghz frequency band. If you need to switch to 2.4Ghz frequency band, please click Enable 2.4G in Air Settings and Reboot. After the setting is completed, switch the Ground terminal to 2.4G in the same way, the aircraft and the remote control will be automatically bound, and the Frequency Band will be displayed as 2.4G. Please fly with caution as control confusion may occur when flying with more than one set of aircraft and remote controllers in the same frequency band.

Remote Controller Overview



- | | | |
|------------------------|-----------------------------|-------------------------------|
| 1. Antennas | 5. Power Button | 9. Function Button 1 |
| 2. Left Control Sticks | 6. Battery Level Indicators | 10. Function Button 2 |
| 3. Flight Pause Button | 7. Touch Screen | 11. Mission Start/Stop Button |
| 4. RTL Button | 8. Right Control Sticks | |

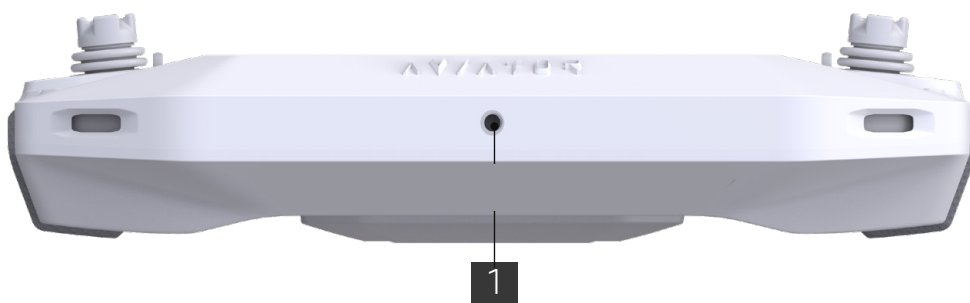

1. Tripod mounting hole (1/4")



1.Customizable C2 Button

2.Customizable C1 Button

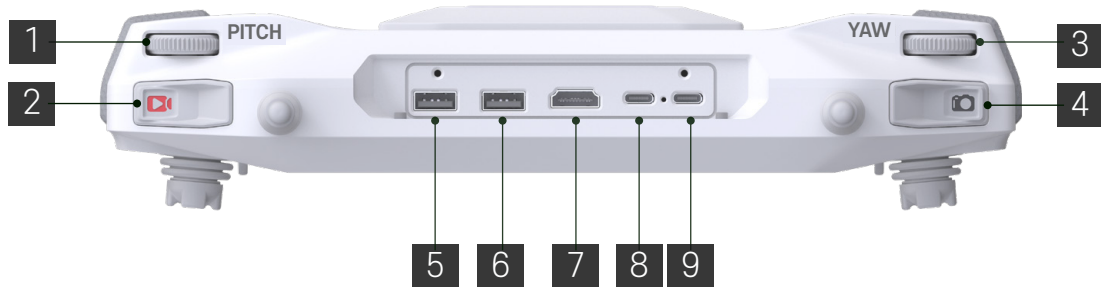

1.Gimbal Yaw Control Dial
2.Record Button
3.Gimbal Pitch Control Dial

4.Photo Button
5.USB Port (debug)
6.USB Port (mouse)

7.HDMI Port
8.Charging USB-C Port
9.External Data Port

Profile

The Remote Controller has a transmission range of up to 3km with controls for camera tilt and photo capture, Has a built-in 7-inch high brightness 1000 cd/m² screen has a resolution of 1920x 1080 pixels, featuring an Android system with multiple functions such as GNSS. In addition to supporting WI-Fi connectivity, it is also compatible with other mobile devices for more flexible usage. The Remote Controller has a maximum working time of 6 hours with the built-in battery.

The Remote Controller can reach maximum transmission distance (FCC) in an unobstructed area with no electromagnetic interference at an altitude of about 400 feet (120 meters). The actual maximum transmission distance may be less than the distance mentioned above due to interference in the operating environment, and the actual value will fluctuate according to the strength of interference.

Maxed operating time is estimated in a lab environment at room temperature, for reference only. When the Remote Controller is powering other devices, the run time will be reduced.

Compliance Standards: The remote controller is compliant with local laws and regulations.

Stick Mode: Controls can be set to Mode 1, Mode 2, Can be customized in FlyDynamics (the default is Mode 2).

*To prevent communication interference, do not fly more than two aircraft within the same area.

*The maximum transmission distance may be smaller than the manual distance due to interference in the actual operating environment, and the actual value may vary depending on interference.

*The maximum operating time is for reference only in a public authentication environment. Running time will be reduced if the remote controller powers other devices.

Preparing the Remote Controller

Charging

Using the official charger, it takes about 2 hours to fully charge under normal temperature shutdown.

Warnings:

Please use the official charger to charge the remote controller.

To keep the remote controller battery in the best condition, please make sure to fully charge the remote controller every 3 months.

Remote Controller Operations

Checking the Battery Level and Turning On

Checking the Battery Level

Check the battery level according to the Battery Levels LEDs. Press the power button once to check it while turned off.

Press the power button once, press again and hold a few seconds to turn on/off the Remote Controller.

Controlling the Aircraft

This section explains how to control the orientation of aircraft through the remote controller, Control can be set to Mode 1 or Mode 2.



Mode1



Mode2

The stick mode is set to mode 2 by default, This manual takes Mode2 as an example to illustrate the control method of the remote control.

RTL Button

Press and hold the RTL button to start Return to Launch(RTL) and the aircraft will return to the last recorded Home Point. Press the button again to cancel RTL.



Optimal Transmission Zone

Make sure the antennas are facing towards the aircraft .

Operating the Camera

Shoot videos and photos with the Photo button and Record button on the remote controller.

Photo (left)/video (right) record button

Press to take a photo/video.

Gimbal operation and control

Use the left dial and right dial to adjust the pitch and pan.



The left dial controls the gimbal Pitch axis.

Turning the dial to the right will control the gimbal clockwise.

When you turn the dial to the left, the gimbal moves counterclockwise.

When the dial is stationary, the camera maintains its current position.



The right dial controls the gimbal Yaw axis.

When you turn the dial to the right, the gimbal moves to face upward.

If you turn the dial to the left, the gimbal will point downward.

When the dial is stationary, the camera maintains its current position.

* AQUILA3 does not operate YAW.



Emergency Stop

Press and hold the **Return button** and **FN1 button** simultaneously for more than 5 seconds to perform an emergency stop of the drone.

Starting/Stopping the Motors

Starting Motors

If you operate the remote controller's stick as shown below, the motor will start.

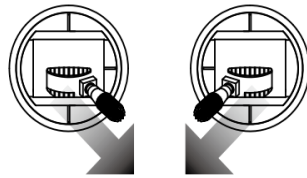

Stopping Motors

Immediately after the aircraft lands, if you pull the left stick downward as shown in the picture, the motor will stop after 2 to 3 seconds.



Emergency Propeller Stop

Click "Disarmed" can be used to execute the emergency propeller stop once the flight controller detects critical error during flight.

1. Place the aircraft in an open, flat area with the battery level indicators facing towards you.
2. Turn on the remote controller, then turn on the aircraft.
3. Launch FlyDynamics App, connect the display device and remote control, and enter the Camera View.
4. Wait until the Aircraft Status Indicators blink red and green alternately.
5. Turn on the motors and push the left stick up slowly to take off.
6. To land, hover over a level surface and gently pull down on the left stick to descend.
7. Turn off the aircraft, then the remote controller.

When the aircraft enters failsafe mode during flight, the aircraft's status LED will quickly light up in amber. When the battery voltage is low (Low Battery Level Warning), the front LED quickly lights up in red and the rear LED lights up in green.

Flight mode

Outline

The Aquila aircraft consists of a remote controller, communication equipment, positioning system, and battery.

Flight mode

The Aquila aircraft supports the following flight modes.

GPS-Position Mode

This is the most common mode for the aircraft. It is used in fields where GPS operates smoothly. The aircraft is controlled using a GNSS-based positioning system. Because the system supports multiband, it can calculate more precise location. Precise posture control is possible.

Altitude Mode

This mode can be used in environments where GPS reception is poor. To control the aircraft's attitude, the altitude of the aircraft is maintained using the altitude value of the barometer instead of the GPS signal. Horizontal control is controlled by the pilot's controls.



Altitude Mode Precautions for use

The aircraft's default flight mode is positioning mode. If the GPS signal is weak or the compass is disturbed by other magnetic fields, it changes to Altitude Mode.

In attitude mode, the aircraft automatically maintains altitude using the altimeter value, so errors in the altimeter value may cause the aircraft to move up or down because it cannot maintain the correct altitude.

And because there is no GPS information needed for horizontal control, the aircraft may flow sideways or be affected by external influences.

In particular, it can be greatly affected by wind. Therefore, the pilot must manually adjust it through the remote controller. Therefore, it may be difficult to fly if you are not an experienced pilot. Therefore, it is best not to fly in places where the GPS signal is weak or there is compass disturbance. It is safe, and if this situation inevitably arises, we recommend that you land the aircraft as quickly as possible.

RTL Mode(1)

RTL Mode (Return to Launch)

RTL mode is a mode that automatically moves the aircraft to the last recorded departure point (Home Point) and lands. There are three RTL modes: Smart RTL, Low Battery RTL, and Failsafe RTL.

Smart RTL

To use Smart RTL mode, press the RTL button on the remote controller for about 2 seconds.

After booting the aircraft, the aircraft status indicator will flash yellow. If you press the Smart RTL button again while RTL is in progress, Smart RTL mode will stop and control of the aircraft will be transferred to the pilot.

Low Battery RTL

If the aircraft's battery power runs out, you may not be able to return to the departure point with the remaining battery power. In this case, the pilot must land the aircraft on the ground as soon as possible. To eliminate the risk of insufficient battery power, the aircraft needs to determine the RTL condition based on the current location information and battery information. If there is not enough battery power remaining, automatic RTL is performed according to the conditions in the table below. You can stop RTL mode by operating the flight mode switch while RTL is in progress. If the pilot disables Low Battery RTL and the remaining battery capacity is less than 5%, the aircraft will be forced to land at its current location. In this case, please be aware that aircraft crash or loss may occur.

Battery level	Explanation	aircraft indicator lights	Flight status
23%	LOW BATTERY warning	Blinks red quickly.	Fly and land while maintaining the current flight mode.
21%	If the distance from the current location to the starting point is less than 500m, the power required to return to the starting point is sufficient.		The pilot judges the situation and lands quickly.
16%	If the distance from the current location to the starting point is less than 500m, the power required to return to the starting point is sufficient.		
5%	The aircraft must land immediately.		

RTL Mode(2)

Failsafe RTL

Failsafe RTL runs automatically when communication is lost between the remote controller and the aircraft for more than 3 seconds.

When Failsafe RTL is executed, the aircraft returns to the departure point by the shortest distance and lands.

Even if communication between the remote controller and the aircraft is restored during RTL, the aircraft continues RTL.

However, the pilot can cancel RTL through the mode switch.

RTL Order

1. Home Point is automatically recorded.
2. RTL is executed. At this time, RTL includes Smart RTL, Low battery RTL, and Failsafe RTL.
3. Once the departure point is confirmed, the aircraft will adjust its direction.
4. If the distance between the aircraft and the departure point is less than 30m, it returns by maintaining the current altitude. If the distance exceeds 30m or the current altitude value is lower than the set RTL altitude value, the aircraft altitude will rise to the set RTL altitude value and then return. If the current aircraft altitude value is higher than the set RTL altitude value, it returns to the starting point immediately.
5. When the aircraft arrives over the departure point, it lands.



Precautions for RTL

You must set the RTL altitude value in the settings menu and make sure that there are no dangerous buildings or objects in the flight area. When returning to RTL and landing, the aircraft will land automatically, but it is recommended that the pilot use the remote controller to slow down the aircraft at the time of landing. During automatic landing, the aircraft may bounce back after touching the ground, so reducing the landing speed is more stable.

RTK Functions

Profile

The aircraft has a built-in RTK , which can withstand magnetic interference from metal structures, ensuring stable flight. More accurate positioning data can be achieved when using a high precision GNSS Mobile Station or Internet network RTK service.

Enable/Disable RTK

Ensure that the "NTRIP RTCM Source" is log in and the RTK service type is correctly set (Mobile Station or Custom Network RTK service) before each use. Go to "RTCM" View to view and set.

Using the Custom Network RTK

You can mount a SIM Card to remote controller or use the app to connect to a wifi, and enable Internet network to use Custom Network RTK. Custom Network RTK can be used to replace the RTK base station. Connect the Custom Network RTK account to the designated Ntrip server to send and receive differential data. Keep the remote controller turned on and the Internet network connected.

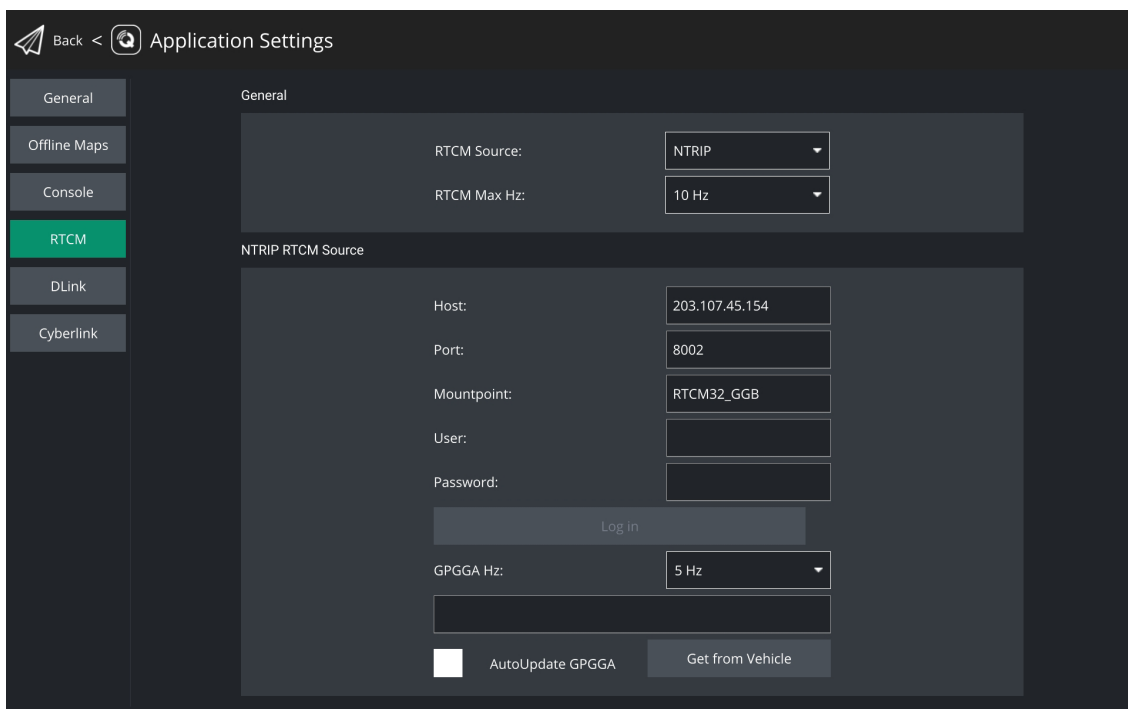

1. Make sure the remote controller turned on and the aircraft are linked , and the app is connected to the Internet network.
2. In RTCM interface, select the RTCM Source type as "NTRIP", fill in NTRIP's Host,Port,Mountpoint,User and Password,and then tap to set by following the instructions.
3. Wait to connect to the Ntrip server. In the Flight main pages, the status of the aircraft's positioning in the status table will show "FIX" to indicate that the aircraft has obtained and used the differential data from the mobile station.

Video Transmission Description

AQUILA uses ARGOSDYNE industry video transmission technology, video, data, and control three-in-one. End-to-end equipment is not restricted by wire control, and maintains a high degree of freedom and mobility in space and distance. With the complete function buttons of the remote control, the operation and setting of the aircraft and the camera can be completed within a maximum communication distance of 10 kilometers. The image transmission system has two communication frequency bands, 5.8GHz and 2.4GHz, and users can switch according to the environmental interference.

Ultra-high bandwidth and bit stream support can easily cope with 4K resolution video data streams. The 200ms screen-to-screen low delay and delay jitter sensitive control are better, which meets the end-to-end real-time requirements of video data. Support H265/H264 video compression, AES encryption.

The adaptive retransmission mechanism implemented at the bottom layer is not only much better than the application layer retransmission mechanism in terms of efficiency and delay, but also greatly improves the performance and user experience of the link in an interference environment.

The module continuously detects the interference status of all available channels in real time, and when the current working channel is interfered, it automatically selects and switches to the channel with the lowest interference to ensure continuous and reliable communication.

Fly Dynamics App

This section introduces the main functions of the FlyDynamics app.

Pre-flight verification procedures

1. The remote controller, aircraft battery, and display unit are fully charged.
2. The landing gear is securely installed and the battery is securely locked.
3. All devices' firmware is up to date.
4. Make sure the microSD card is inserted into the camera.
5. After powering on, the camera and gimbal work normally.
6. The motor is spinning and operating normally.
7. The Fly Dynamics app has successfully connected to your drone.
8. To prevent dust or water from entering the battery connector, do not point the battery connector toward the ground.
9. Check that the gimbal damper is free of wear and that the gimbal fastener is properly fastened.

Fly Dynamics App

FlyDynamics App is specially designed for industry applications. Manual flight integrates a variety of professional functions, and the operation is simple and efficient. Route flight can set the route through the flight planning function, control the drone to operate autonomously, simplify the workflow and improve work efficiency.

Manual Flight

Camera View

The description below use a Z10TIR gimbal and camera as an example. The Camera View may vary when using other gimbals and cameras.



1.Main menu

Sliding down the menu, choose to enter the Aircraft Settings、 App Settings.

2.Flight Mode

Display the current flight mode. Sliding down the menu to switch the flight mode (Altitude/Position/Mission/Return).

3.Aircraft status

Display the current aircraft status. Sliding down the menu to check the status of each sensor.

4.GNSS Status

Shows the strength of the GNSS signal. If the RTK function of the aircraft is turned on, "RTK" will be displayed. Sliding down the menu to display the GPS Count, GPS lock, HDOP, VDOP and Course Over Ground.

5.Battery Status

Remaining battery percent. Sliding down the menu to display the current Battery Voltage and Accumulated Consumption.

6.Operating Frequency

Display the communication frequency band and signal strength.

7.Message Box

Sliding down the menu to read all warning messages.

8.Smart Track

Click to disable/enable Smart Track. When using the Z10TIR/Z40TIR or Q10T, the Smart track function can be used to lock and track targets such as people, cars, boats, or other objects. After locking the target, it will automatically control the gimbal to rotate, so that the target can be located in the center of screen, and adjust the camera focal length to an appropriate focus rate to track and view the target.

9.Wide Camera View

Display the Wide Camera view.

10.Map

Tap to view the map. Read the "Map flight View" section for more information.

11.Infrared Camera View

Display the Infrared Camera view.

12.Zoom

Display the camera zoom rate, Click "+" and "-" to adjust the zoom magnification of the zoom camera. Click "reset zoom" and the camera will automatically return to its original state.

13.Display the current remaining capacity of the memory card.

14.Grid

Display the tilt axis angle of the gimbal. ($-90^{\circ} \sim 45^{\circ}$)

15.Shutter/Record Button

Tap to shoot photos or start/stop recording.

16.Display the current camera model and the number of photos/recording time.

17.Parameter Settings

Tap to enter the photo and video settings.

18.Parameter Settings

Tap to enter the photo and video settings.

19.Fusion method

Tap to switch the view of Infrared Camera and Wide Camere.

20.Primary Flight Display/Navigaton Display

Display the current total flight time, total flight mileage, flight speed, ascent speed, descent speed, the altitude, and the relative distance between the aircraft and the remote control.

Map Flight View

Quickly switch to the map interface by tapping the map icon in the lower left corner of the main screen.

Note: To ensure the normal use of the map function, please connect to the network in advance to cache the map.

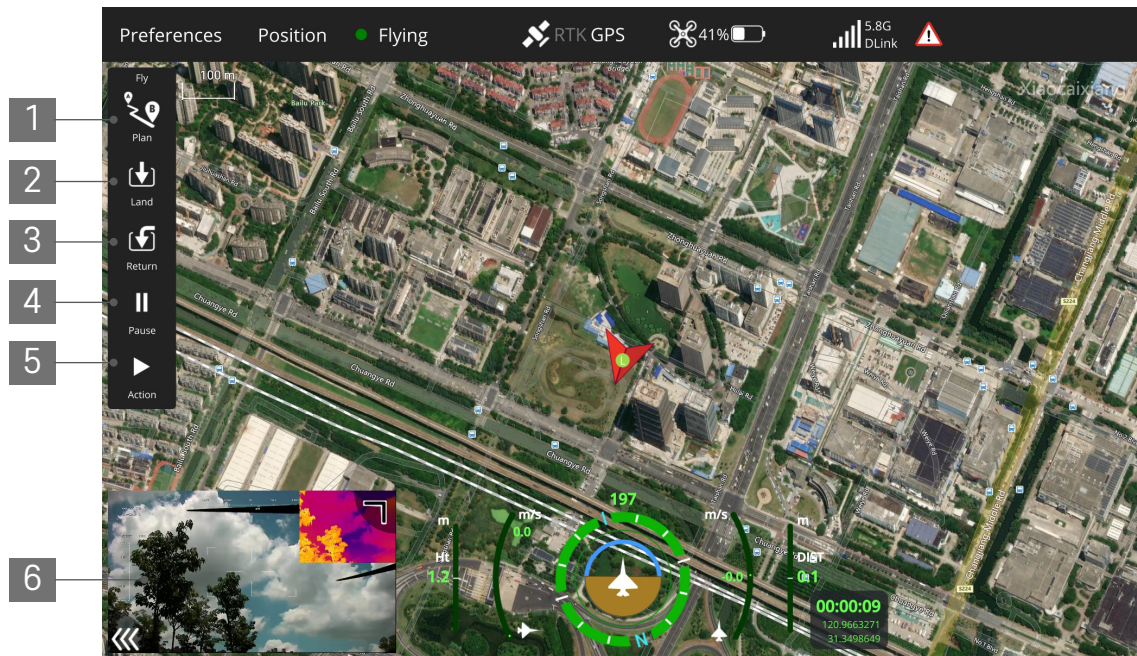

1. Plan

The Plan View is used to plan autonomous missions for your vehicle, and upload them to the vehicle. Once the mission is planned and sent to the vehicle, you switch to the Fly View to fly the mission.

2. Land

You can land at the current position at any time while flying.

3. Return

Return to the home position at any time while flying.

4. Pause

You can pause most operations, including taking off, landing, RTL, missions, Orbit at location.

5. Action

Tap to continue the mission.

6. Camera View

Mission Flight

Introduction

AQUILA is designed for automatic flight, scanning, mapping, surveying and other stable flight modes, and is used for high-precision image acquisition and post-processing preparation.

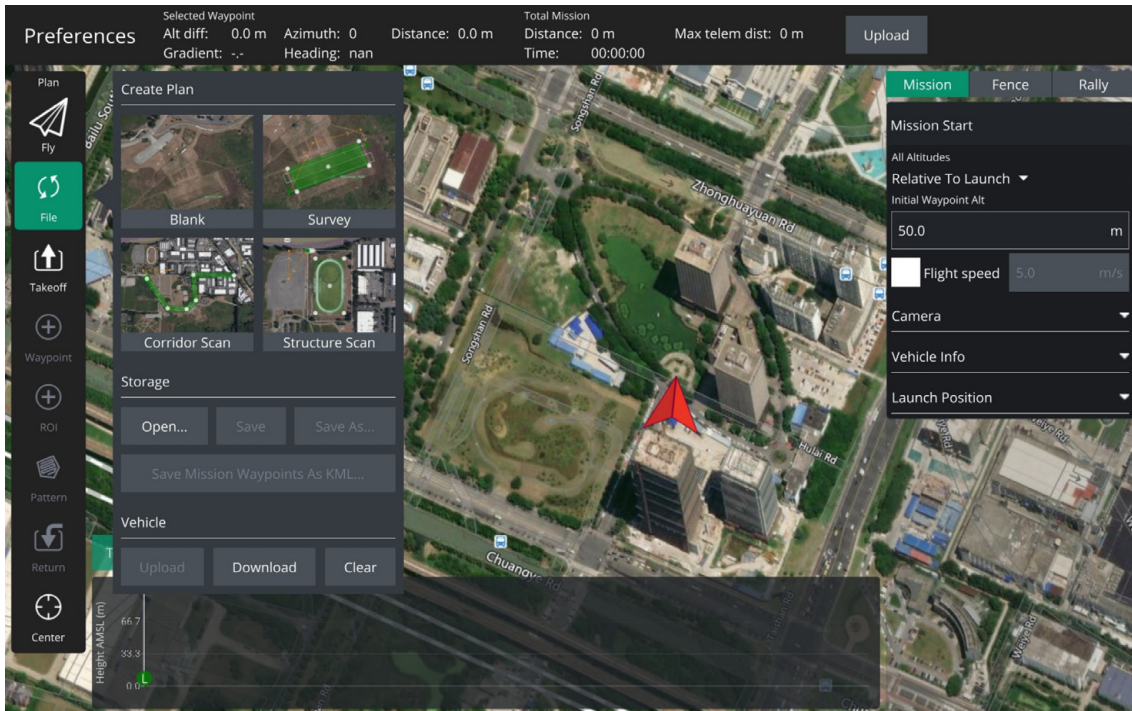

1.File

The File tools are used to move missions between the ground station and vehicle, and to save/restore them from files.

The File tools provide the following functionality:

Upload (Send to vehicle);

Download (Load from vehicle);

Save/Save as to File, including as KML file;Load from File;

Clear All (Clear all mission waypoints from Plan view and from vehicle).

2. Take off

Tap to set the mission Takeoff point.

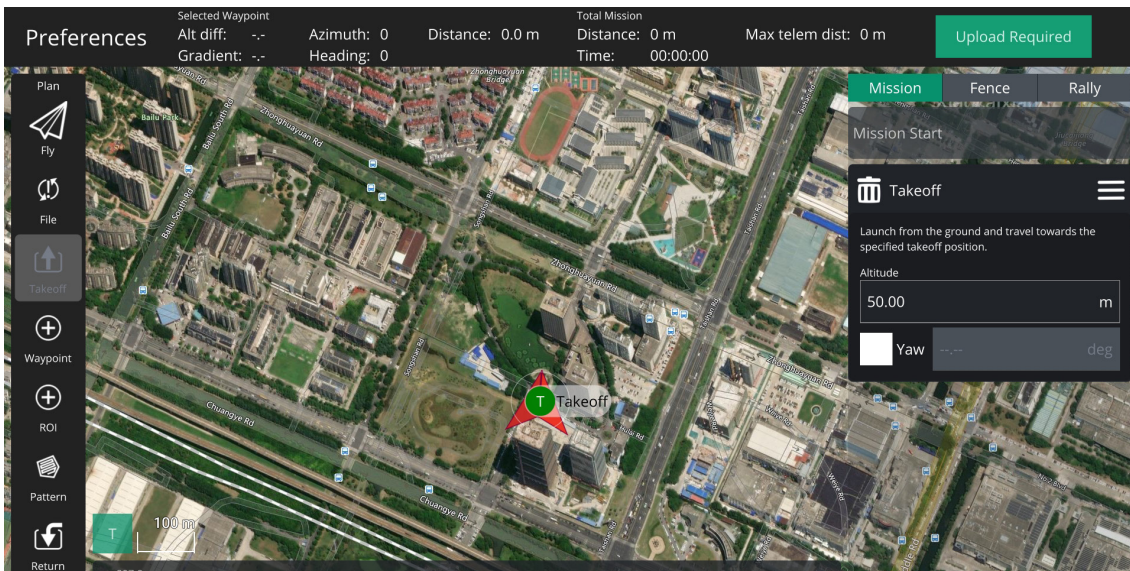

3. Waypoint

Click on the Add Waypoint tool to activate it. While active, clicking on the map will add new mission waypoint at the clicked location. The tool will stay active until you select it again. Once you have added a waypoint, you can select it and drag it around to change its position.

Each waypoint mission contains mission instructions, such as Take photo or Start recording video at a certain waypoint, setting zoom multiple, setting the pitch and yaw angles of the Gimbal, flight speed, and altitude, etc.

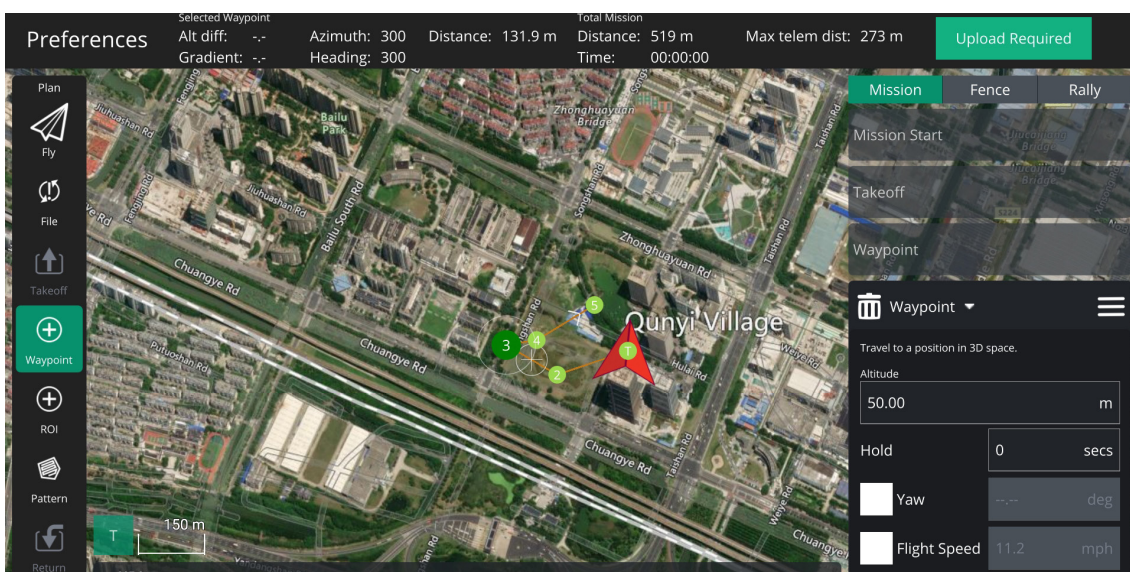

4.ROI

Tap to add a ROI point, the front of aircraft (or nose) will always towards to the ROI point all along during the mission flight.

5.Pattern

The Pattern tool simplifies the creation of missions for flying complex geometries, including Survey, Corridor Scan and Structure Scan, Which can provide a full solution for any surveying, mapping or inspection workflow.

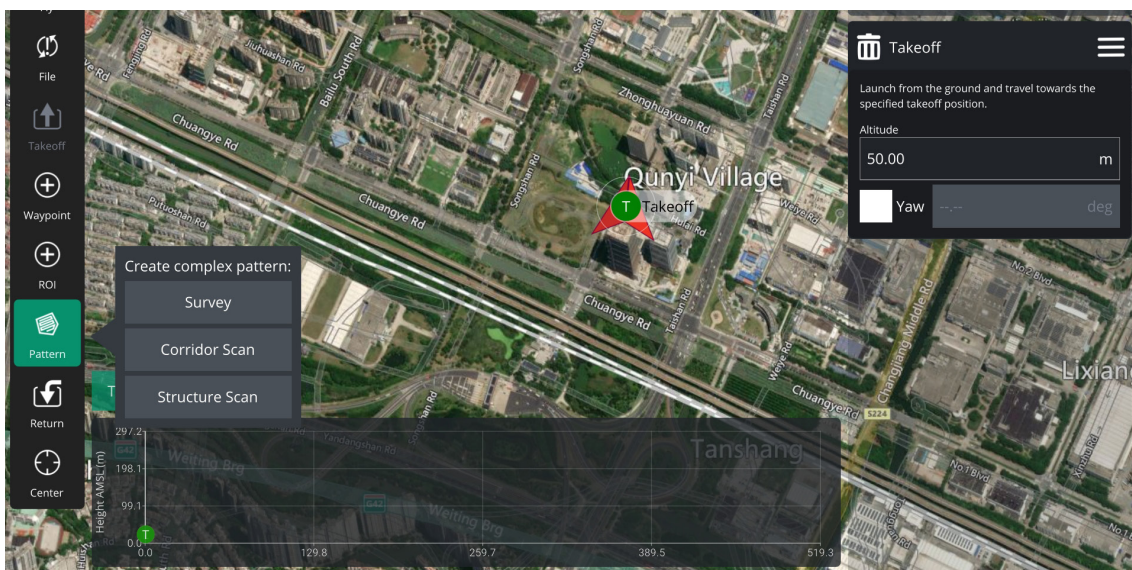

Survey

A survey allows you to create a grid flight pattern over a polygonal area. You can specify an arbitrary polygon, the angle and other properties of the grid, and camera settings appropriate for creating geotagged images.

Corridor Scan

A corridor scan allows you to create a flight pattern that follows a poly-line. This can be used to, for example, survey a road.

Structure Scan

A Structure Scan allows you to create a grid flight pattern that captures images over vertical surfaces (e.g. walls) around a structure with an arbitrary polygonal (or circular) ground footprint. Structure Scans are typically used for the visual inspection or creating 3d models of structures.

A. Survey:

Choose the Pattern Tool from the Plan Tools and then select Survey.

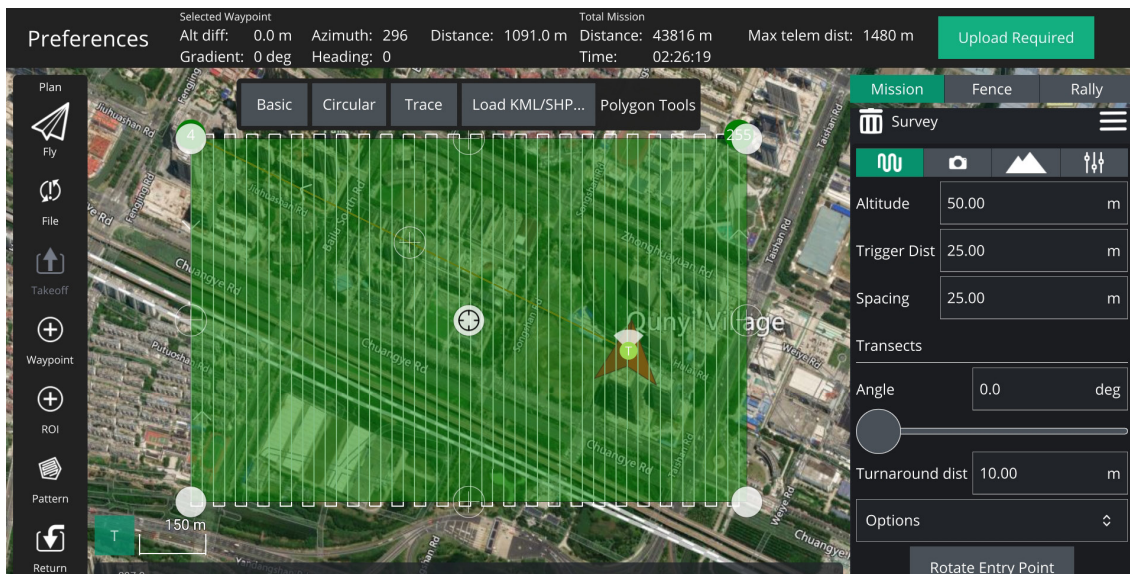

For different operating environments, in the Survey, we provide three graphics options, Basic, Circular, Trace, and you can also choose to import KML files.

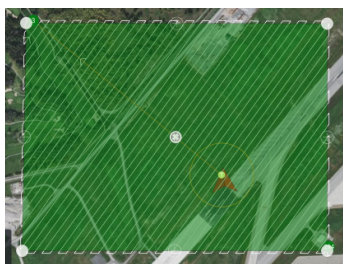

Basic



Circular



Trace

This will add a survey grid to the map, and a Survey item to the mission list (on the right).

On the map drag the vertices to the change the shape of the polygon.

Click the (+) symbol between existing vertices to create a new vertex. The new vertex can then be dragged into a new position.

The survey can be further configured in the associated mission item (in the mission item list on the right hand side of the Plan View).

Front Lap/Side Lap: Overlap between each image capture. This can be configured separately for when flying along grid lines or across them.

Altitude: Survey altitude (ground resolution will be calculated/displayed for this altitude).

Ground Res: Ground resolution for each image (altitude required to achieve this resolution calculated and shown).

Transects: The Transects section is used for grid settings that are independent of the camera used.

The configurable options are:

Angle: The angle of the grid lines, relative to North.

Turnaround dist: Amount of additional distance to add outside the survey area for vehicle turn around.

Rotate Entry Point: Press button to swap the start and end point of the survey.

Hover and capture image:

Hover to capture images (multicopter only).

Refly at 90 degree offset:

Check to refly the whole mission at a 90 degree offset.

Images in turnarounds:

Check to take images when turning.

Terrain: By default, a flying vehicle will follow the survey path at a fixed altitude. Enabling Terrain Following makes the vehicle maintain a constant height relative to ground.

Statistics: The Statistics section shows the calculated survey area, photo interval, trigger distance, photo spacing and planned photo count.

Camera: Camera triggering behaviour depends on the camera/camera settings. You can select an existing camera, custom camera, or manually enter the settings.

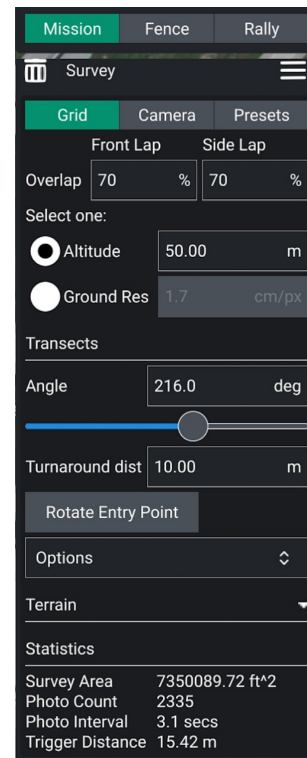

B. Corridor Scan

Choose the Pattern Tool from the Plan Tools and then select Corridor Scan.

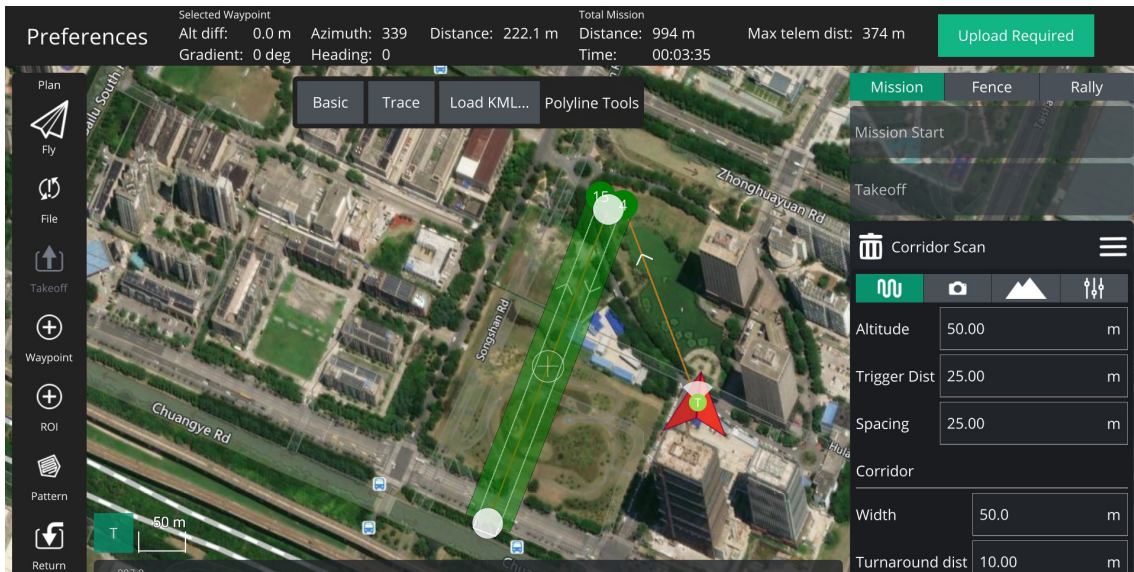

In the Corridor Scan, we can choose the Basic /Trace graphics or import KML files.



Basic



Trace

This will add a corridor to the map, and a Corridor Scan item to the mission list (on the right). On the map drag the ends of the corridor to the start and end positions of the scan, respectively

Click the (+) symbol at the centre of a line to create a new vertex. The new vertex can then be dragged into position to follow the path of the desired corridor.

The corridor scan can be further configured in the associated mission item (in the mission item list on the right hand side of the Plan View).

Front Lap/Side Lap: Overlap between each image capture. This can be configured separately for when flying along grid lines or across them.

Altitude: Survey altitude (ground resolution will be calculated/displayed for this altitude).

Ground Res: Ground resolution for each image (altitude required to achieve this resolution calculated and shown).

Width: Set the width of the scan around the polyline that defines the path.

Turnaround dist: Amount of additional distance to add outside the survey area for vehicle turn around. Options: Check to enable image capture a turnaround points.

Terrain: By default a flying vehicle will follow the corridor path at a fixed altitude. Enabling Terrain makes the vehicle maintain a constant height relative to ground.

Statistics: The Statistics section shows the calculated survey area, photo interval, photo spacing and planned photo count.

Camera: Camera triggering behaviour depends on the camera/camera settings. You can select an existing camera or manually enter the settings.

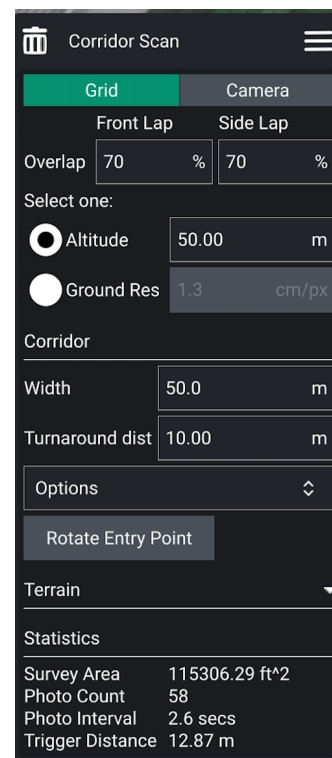

C. Structure Scan:

Choose the Pattern Tool from the Plan Tools and then select Structure Scan.

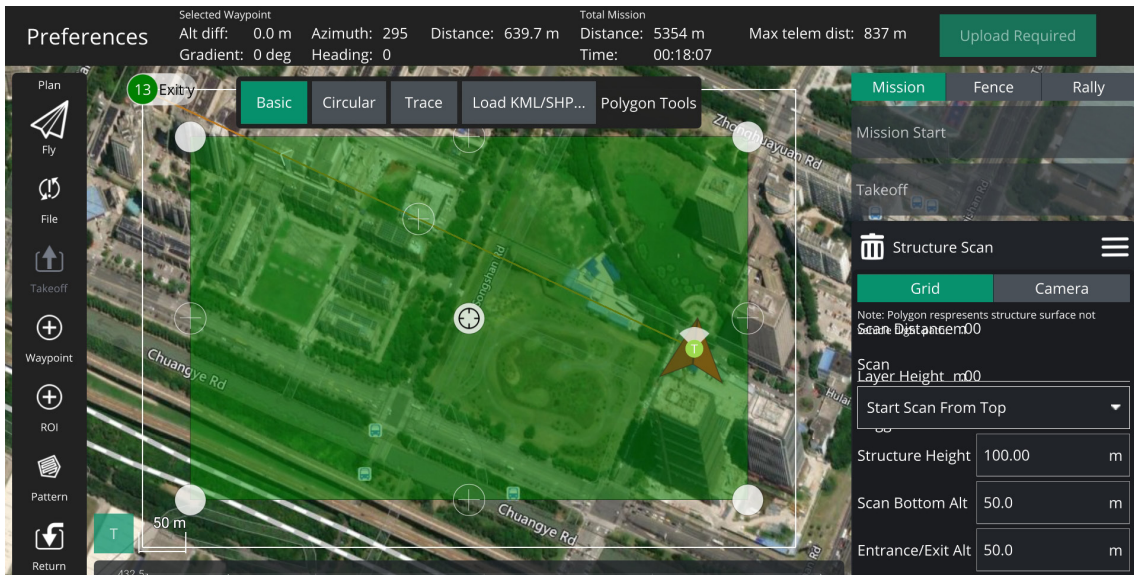

In the Structure Scan, we can choose the Basic/Circular/Trace graphics or import KML files.



Basic



Circular



Trace

This will create a simple square structure scan on the map. The region shown in green must be modified so that it surrounds the structure.

You can also change to a circular footprint by clicking on the central "vertex" (marked in white) and selecting Circle in the popup menu.

The rest of the configuration is handled using the Structure Scan editor on the right hand side of the view. First select whether you want to perform a manual scan, a scan using a particular camera, or a scan using a custom camera definition.

Front Lap: Image overlap from top to bottom (increasing shrinks layer height and increases layer count).

Side Lap: Image overlap at sides (increasing takes more images in each lap/layer scan).

Scan distance: Distance from the structure of the flight path.

Ground Res: Required image resolution/sample quality of surface.

Start scan from top/bottom: The direction in which layers are scanned.

Structure Height: The height of the object being scanned.

Scan Bottom Alt: Use this setting to avoid obstacles around the base of the structure. This adjust the bottom of the structure to be above the ground, and hence the altitude of the first scan (the height of the lowest layer flight path is shown in the scan statistics as Bottom Layer Alt).

Entrance/Exit Alt: Use this setting to avoid obstacles between the last/next waypoint and the structure to be scanned.

The vehicle will fly to the Entrance/Exit point at this altitude and then descend to the initial layer to start the scan.

The vehicle will ascend to this altitude after completing the scan and then move to the next waypoint.

Rotate entry point: Move the start/finish point to the next vertex/position on the flight path.

Statistics: The Statistics section shows the Layers, Layer Height, Top Layer Alt, Bottom Layer Alt, Photo Count, Photo Interval and Trigger Distance.



6. Return

Tap to "Return" to set the automatic return to the take-off point after completing the mission.

7.Center

Tap to "Center" can navigate to the center of the map. Center map on Mission, All items, Launch, Vehicle, Current Location or Specified Location (As shown on the right, if you choose, you can input detailed coordinate points and locate the target point).

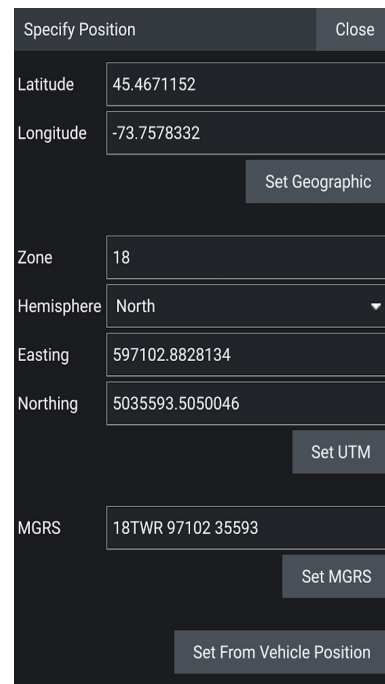

The image shows a 'Specify Position' dialog box with a 'Close' button in the top right corner. It contains several input fields and buttons:

- Latitude: 45.4671152
- Longitude: -73.7578332
- Set Geographic button
- Zone: 18
- Hemisphere: North (dropdown menu)
- Easting: 597102.8828134
- Northing: 5035593.5050046
- Set UTM button
- MGRS: 18TWR 97102 35593
- Set MGRS button
- Set From Vehicle Position button

8. Plan Toolbar

Status information for the currently selected waypoint relative to the previous waypoint, as well as statistics for the entire mission (e.g. horizontal distance and time for mission). Max telem dist is the distance between the Planned Home and the furthest waypoint.

When connected to a vehicle it also shows an Upload button, can be used to upload the plan to the vehicle.

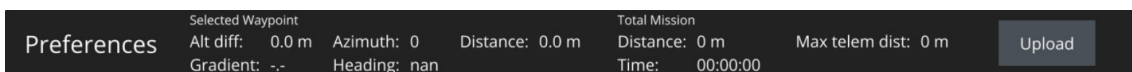

The image shows a 'Plan Toolbar' with the following information:

Preferences	Selected Waypoint				Total Mission	
	Alt diff: 0.0 m	Azimuth: 0	Distance: 0.0 m	Distance: 0 m	Max telem dist: 0 m	Upload
	Gradient: -	Heading: nan		Time: 00:00:00		

9. Mission Command List

Mission commands for the current mission are listed on the right side of the view. At the top are a set of options to switch between editing the mission, GeoFence and rally points. Within the list you can select individual mission items to edit their values.

Mission Start : The Mission Start panel is the first item that appears in the mission command list. It may be used to specify a number default settings that may affect the start or end of the mission.

Fence: GeoFences allow you to create virtual regions within which the vehicle can fly, or in which it is not allowed to fly. You can also configure the action taken if you fly outside permitted areas.

Rally: Rally Points are alternative landing or loiter locations. They are typically used to provide a safer or more convenient (e.g. closer) destination than the home position in Return/RTL mode.



Mission

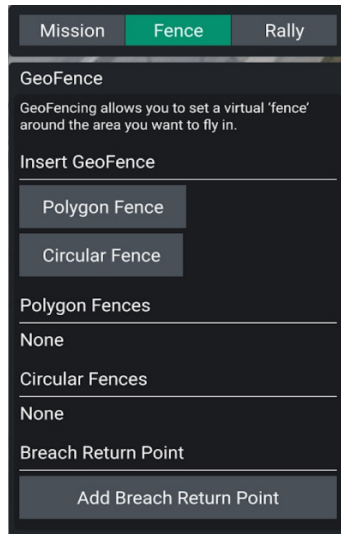

Fence

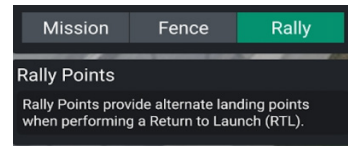

Rally

Aircraft Settings

Summary

An overview of all the important setup options for your vehicle. Similar to the individual setup buttons, the summary blocks show a red indicator when those settings are not fully configured.

Airframe

Specify the airframe type for the vehicle. This page allows you to configure the main airframe selection associated with your vehicle. The view/process differs slightly based on the flight controller firmware used.

Sensors

The Sensor Setup section allows you to configure and calibrate the vehicle's compass, gyroscope, accelerometer and any other sensors.

Available sensors are displayed as a list of buttons beside the sidebar. Sensors marked with green are already calibrated, while sensors marked with red require calibration prior to flight. Sensors with no light are simple settings with default values that you may choose not to calibrate. Please refer to the section "Sensor Calibration" for specific usage.

Radio

Radio Setup is used to configure the mapping of your main transmitter attitude control sticks (roll, pitch, yaw, throttle) to channels, and to calibrate the minimum, maximum, trim and reverse settings for all other transmitter controls/RC channels. Please refer to the section "Radio Calibration" for specific usage.

Sensors Calibration

The Sensor Setup section allows you to configure and calibrate the vehicle's compass, gyroscope, accelerometer and any other sensors (the available sensors will depend on the vehicle type).

Available sensors are displayed as a list of buttons beside the sidebar. Sensors marked with green are already calibrated, while sensors marked with red require calibration prior to flight. Sensors with no light are simple settings with default values that you may choose not to calibrate.

Click on the button for each sensor to start its calibration sequence.

Compass :

The process guides you to position the vehicle in a number of set orientations and rotate the vehicle about the specified axis.

The calibration steps are:

1. Click the Compass sensor button and click OK to start the calibration.

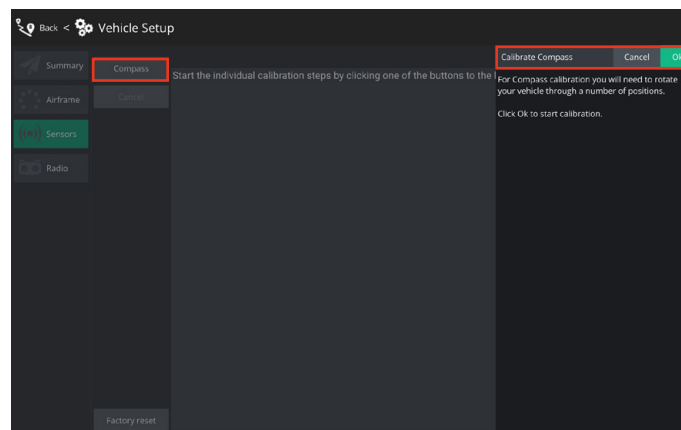

2. Place the vehicle in any of the orientations shown in red (incomplete) and hold it still. Once prompted (the orientation-image turns yellow) rotate the vehicle around the specified axis in either/both directions. Once the calibration is complete in that orientation the associated image on the screen will turn green.

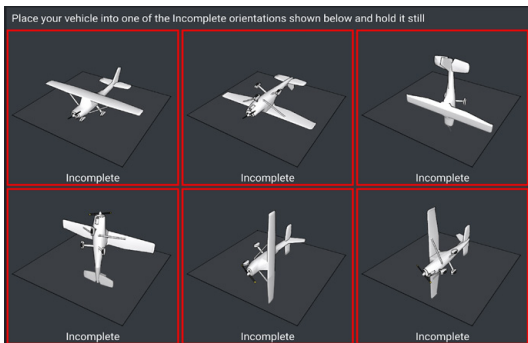

1

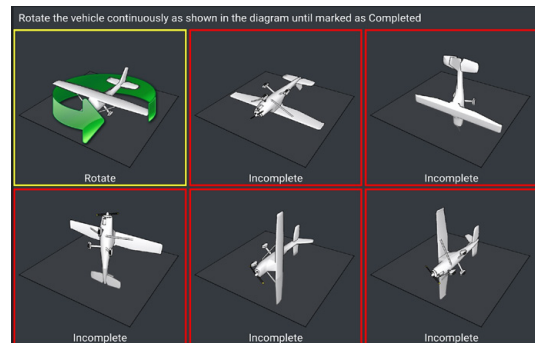

2

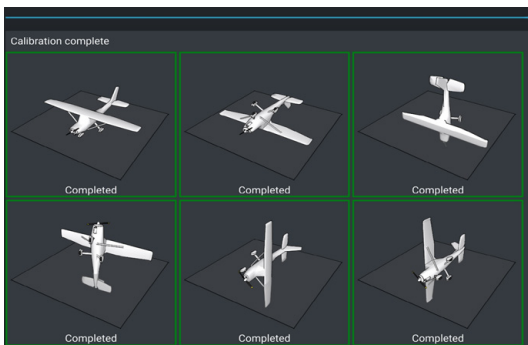

3

3. Repeat the calibration process for all vehicle orientations.

Once you've rotated the vehicle in all the positions FlyDynamics App will display Calibration complete (all orientation images will be displayed in green). You can then proceed to the next sensor.

If the calibration fails, keep the aircraft away from metal objects and perform the calibration again.

Note: If all the LED lights flash red quickly, it indicates that the geomagnetic calibration has failed, and the calibration process can be repeated. If the calibration continues to fail, please select the calibration location again.

Important note: Do not calibrate in areas with strong magnetic fields or near large pieces of metal, and do not carry ferromagnetic materials with you.

Radio Calibration

You need to move the sticks in a specific pattern that is shown on the transmitter diagram on the top right of the screen. Simply follow the instructions to complete calibration.

To calibrate the radio:

1. Select the Gear icon (Vehicle Setup) in the top toolbar and then Radio in the sidebar.
2. Turn on your RC transmitter.
3. Press OK to start the calibration.

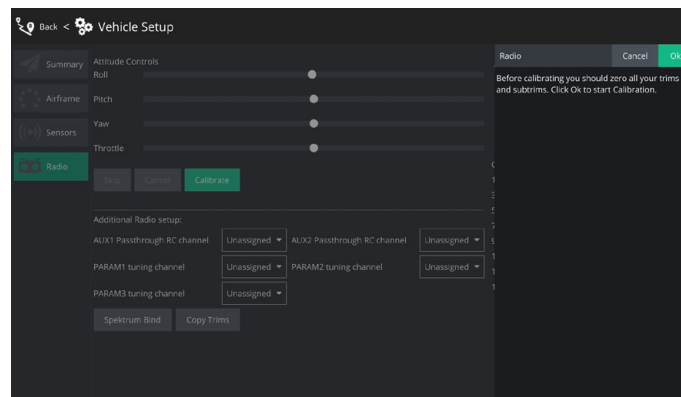

4. Set the transmitter mode radio button that matches your transmitter configuration (this ensures that FlyDynamics displays the correct stick positions for you to follow during calibration).

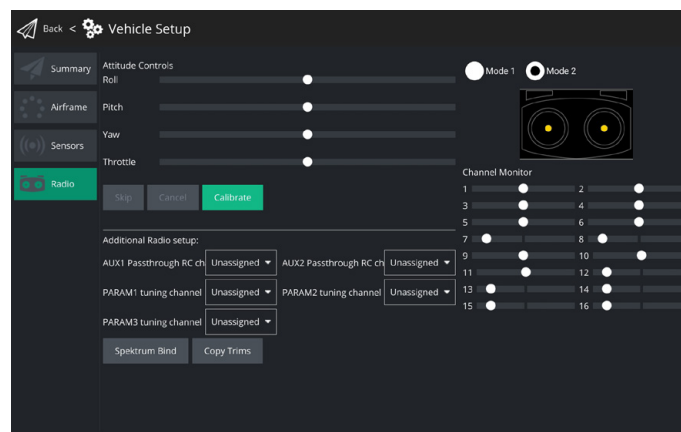

5. Move the sticks to the positions indicated in the text (and on the transmitter image). Press Next when the sticks are in position. Repeat for all positions.

6. When prompted, move all other switches and dials through their full range (you will be able to observe them moving on the Channel Monitor). Press Next to save the settings.

Application Settings

General

The main application configuration settings. These are used to specify: display units, autoconnection devices, video display and storage, RTK GPS, etc.

Fly View:

Use Preflight Checklist:

Enable pre-flight checklist in Fly toolbar.

Enforce Preflight Checklist:

Checklist completion is a pre-condition for arming.

Keep Map Centered on Vehicle:

Forces map to center on the currently selected vehicle.

Show Telemetry Log Replay Status Bar:

Display status bar for Replaying Flight Data.

Virtual Joystick:

Enable virtual joysticks (PX4 only).

Use Vertical Instrument Panel:

Align instrument panel vertically rather than horizontally (default).

Show additional heading indicators on Compass:

Adds additional indicators to the compass rose:

Blue arrow: course over ground.

White house: direction back to home.

Green line: Direction to next waypoint.

Lock Compass Nose-Up:

Check to rotate the compass rose (default is to rotate the vehicle inside the compass indicator).

Guided Minimum Altitude:

Minimum value for guided actions altitude slider.

Guided Maximum Altitude:

Minimum value for guided actions altitude slider.

Go To Location Max Distance:

The maximum distance that a Go To location can be set from the current vehicle location (in guided mode).

Plan View :

The default altitude used for the Mission Start Panel, and hence for the first waypoint.

Units:

This section defines the display units used in the application.

Miscellaneous:

This section defines a number of miscellaneous settings, related to (non exhaustively): font sizes, colour schemes, map providers, map types, telemetry logging, audio output, low battery announcement levels, default mission altitude, virtual joysticks, mission autoloading, default application file load/save path etc.

Telemetry Logs from Vehicle

Save log after each flight:

Telemetry logs (.tlog) automatically saved to the Application Load/Save Path (above) after flight.

Save logs even if vehicle was not armed:

Logs when a vehicle connects to FlyDynamics App. Stops logging when the last vehicle disconnects.

Save CSV log of telemetry data:

Log subset of telemetry data to a CSV file.

AutoConnect to the following devices:

Settings include:

Pixhawk: Autoconnect to Pixhawk-series device

SiK Radio: Autoconnect to SiK (Telemetry) radio

PX4 Flow: Autoconnect to PX4Flow device

LibrePilot: Autoconnect to Libre Pilot autopilot

UDP: Autoconnect to UDP

RTK GPS: Autoconnect to RTK GPS device

RTK GPS:

This section allows you to specify the RTK GPS "Survey-in" settings, to save and reuse the result of a Survey-In operation, or to directly enter any other known position for the base station.

ADSB Server:

FlyDynamics can consume ADSB messages in SBS format from a remote or local server (at the specified IP address/port) and display detected vehicles on the Fly View map.

Offline Maps

Allows you to cache maps for use while you have no Internet connection.

Console

The Console can be helpful tool for diagnosing FlyDynamics problems.

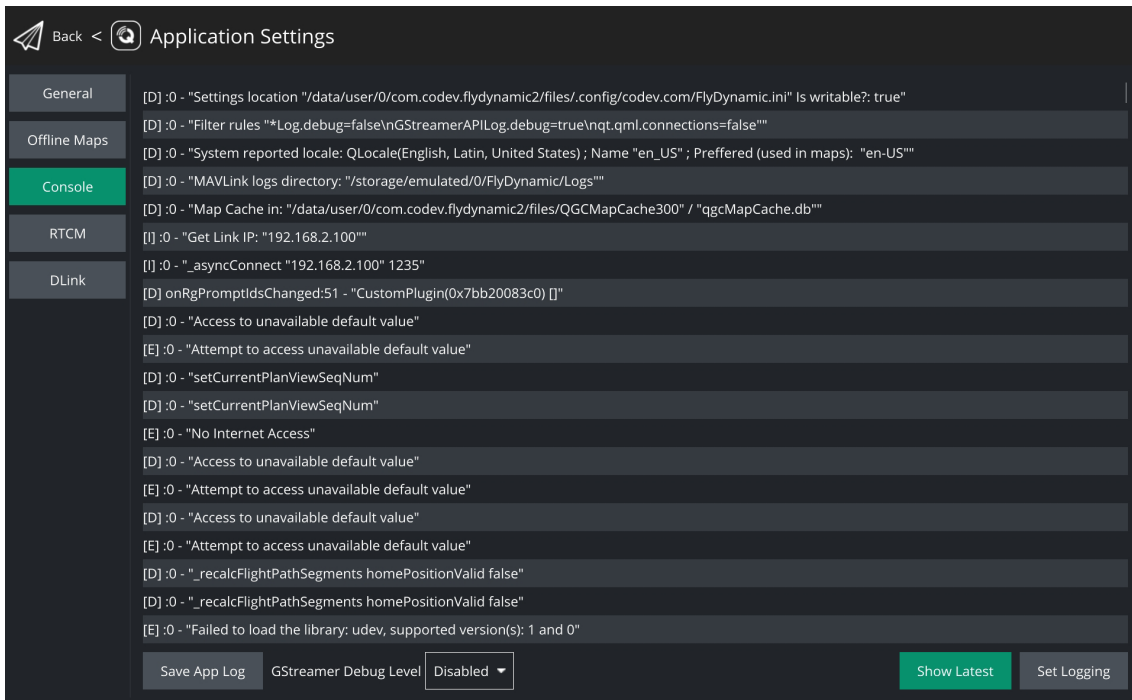

Click the Set Logging button to enable/disable logging information displayed by FlyDynamics.

RTCM

RTK differential data transmission. Please refer to the section "RTK Function" for specific usage.

DLink

The aircraft is bound to the remote controller. For specific binding methods, please refer to the section "Linking the Remote Controller".

Flight

This section describes flight restrictions and safe flight practices.

Precautions when storing the controller

Precautions when storing the controller

- Be careful not to press the joystick of the AVIATOR controller.
- Store the AVIATOR controller antenna separately to prevent damage.
- When storing for a long period of time, keep the battery remaining at 30 to 50% to prevent it from discharging.

Controller appearance inspection

Controller appearance inspection

- Make sure that the AVIATOR controller joystick is in a neutral state when not touched.



- Be sure to fasten the AVIATOR antenna correctly to prevent it from falling out during flight.

Appendix

Remote Controller	AVIATOR
Operating Frequency(ENPULSE)	2.4000 - 2.4835 GHZ; 5.725-5.850 GHz
Max Transmitting Distance (unobstructed, free of interference)	3km
Dimensions	284x150x63mm
Weight	1100g
Operating system	Android10
Built-in battery	7.4V 10000mAh
Battery Life	4.5h
Touch screen	7 inch 1080P 1000nit
I/Os	2*USB、 1*HDMI、 2*USB-C
Operating Environment	-10° C to 40° C
Wireless LAN	WIFI(2.4G(802.11.n), 5G(802.11.n,ac))
IP Level	IP43

App updates

FlyDynamics App updates

Prepare a new app file. Save the app file to a USB storage device and connect it to the remote controller. Select the file in File Manager and run it.

Customer Support Center

ARGOSDYNE Customer Support Center

☎ 070-5102-1388

For any inquiries regarding the construction of the Aquila 2 drone and drone automatic operation system - Rondo Mobility System, please use the ARGOSDYNE Customer Support Center.

※ For customers who use communication networks such as LTE/wifi through the Rondo Mobility System, problems that arise related to the use of rate plans, etc. can be resolved by contacting the telecommunication company with which you have a contract.

Product maintenance

The free maintenance period for the Aquila 2 drone is one year from the date of purchase. Except in cases where there is a defect in the product itself, free support is not provided for matters caused by the user's negligence or natural disasters.

Feedback about this document

If you would like to help us improve this document, please send suggestions, comments, or errors to info@argosdyne.com.



If damage to the product occurs due to a change in the intended use of this product or a change in the settings, we will not be held liable due to the customer's negligence.

Argosdyne Co., Ltd. (Representative : Jeong Seung-ho)

Business number: 466-86-00994

Address: A-1306, 58-1 Giheung-ro, Giheung-gu, Yongin-si, Gyeonggi-do,
Republic of Korea

Tel. 070-5102-1388 | Fax. 031-274-5041 | Web. www.argosdyne.com

